

# Workplace Designs

Architecture | Project Consultancy | Furniture | CAD & Graphics

# WDL AMP

Agile Meeting Pod



As a space in space product,

What should **AMP** look like?



## TRUE FLEXIBILITY

Excellent sound insulation;

High sound absorption;

Efficient ventilation.



## VENTILATION

Hot air rises and cold air falls. This simple principle is the basis for the development of our ventilation systems.

This system directs air within the enclosure from the bottom, guiding it upwards through the walls. Warm air is expelled through ceiling fans.

For the AMP-01 POD, we have 2 fans;  
The AMP-02 POD has 4 fans;  
Finally, the AMP-04 POD has 16 fans.

Stay cool under pressure

60 Seconds

Air Replaced Every Minute

The airflow inlet at the bottom continuously brings in fresh air, while the two fans at the ceiling exhaust the warm air, ensuring the indoor air remains fresh at all times.



## ACOUSTICS

In an open space, many different activities have their own noise levels, and colleagues' conversations are the main source of noise for employees who are trying to focus on their work.

People can make phone calls or focus on their work in AMP and isolate themselves from the surrounding environment, enjoy an independent and quiet space, and also not disturb other colleagues.

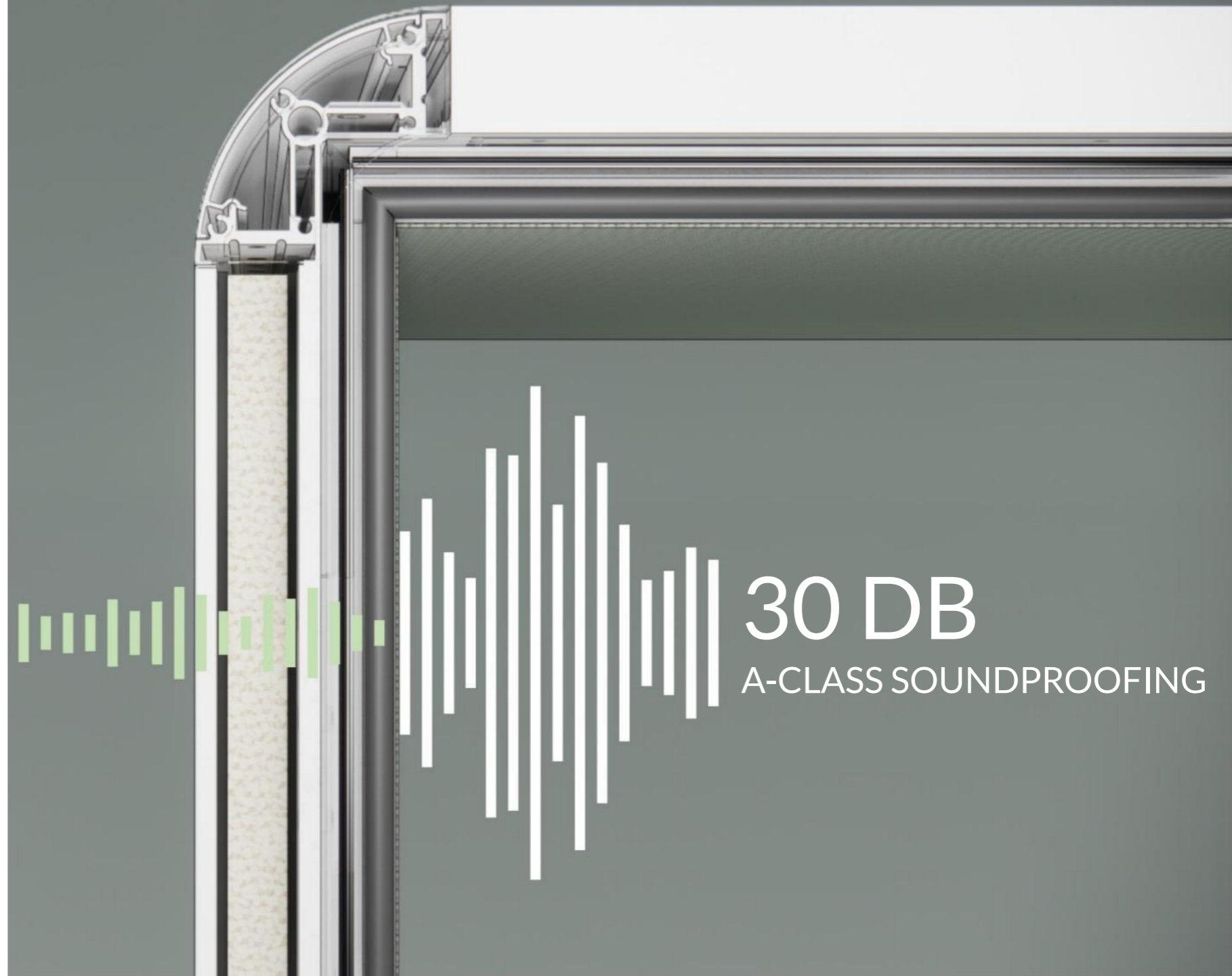

## TRUE FLEXIBILITY

As a global leader in integrated mobile wheel office pods, we have observed that in just a few years, wheels have become a standard feature, and the flexibility of office pods is starting to be valued. However, does having wheels and being mobile represent complete flexibility?

True flexibility, should be:

The product's finishes can be changed freely and quickly;

The product's structure must support the free configuration of furniture;

The product's structural design must be conducive to global operations.

Move to different locations on the same floor using hidden built-in wheels. AMP's structure supports quick and repeated dismantling and reassembly for flexibility to move on different floors/sites.



## AMP Finishes can be changed freely the first one in the world.

The AMP product allows customers to customise the finishes with a wide range of options.

Unlike common PODs on the market, which limit colour options and cannot be changed once purchased, AMP offers unparalleled freedom and flexibility, as the internal fabric can be changed, if desired a year or two after installation (POA).

Our innovative design allows for easy and hassle-free finish changes throughout the pod's lifecycle, giving customers the power to adapt their work environment to their evolving needs.

Experience true freedom in office design with AMP finishes.



## AMP - allows customers to customise the furniture.

AMP has completely realised the freedom to configure furniture;

The internal structure of the product presets a very large number of socket installation locations;

Unique primary and secondary wiring channels support flexible and smooth wiring;

Supporting the installation of doors without restrictions on location, direction and quantity;

Pre-set embedded positions for easy installation of furniture, equipment and accessories.





## Phone POD

AMP01

### Description:

Interior fabric: A-28

Exterior Fabric: A-28

Edge: Similar colour as fabric

Furniture: L-shaped shelf

### Outlet locations:

The 3<sup>rd</sup> panel on the left wall.

Dimmer switch (1), Data (1)

Power (1), USB (1)

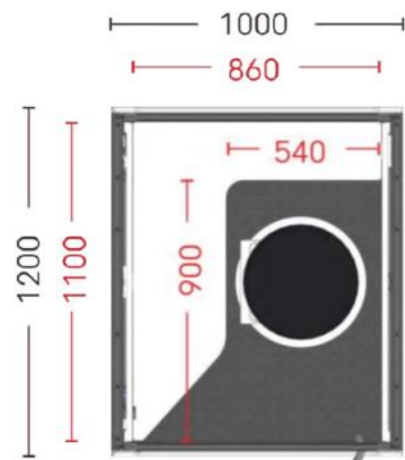

## Phone POD/Studio

AMP01

### Description

Interior fabric: A-28

Exterior Fabric: A-28

Edge: Similar colour as fabric

Furniture: Table + Shelf

### Outlet locations:

The 3<sup>rd</sup> panel on the left wall.

Dimmer switch (1), Data (1)

The 3<sup>rd</sup> panel on the right wall.

Power (1), USB (1)

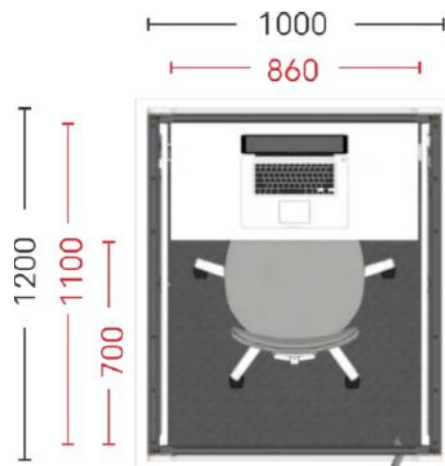

## Studio/Small office

AMP02

### Description

Interior fabric: A-28

Exterior Fabric: A-28

Edge: Similar colour as fabric

Furniture: Table + Shelf + White board

### Outlet locations:

The 3<sup>rd</sup> panel on the right wall.

Dimmer switch (1), Data (1), Power (1), USB (1)

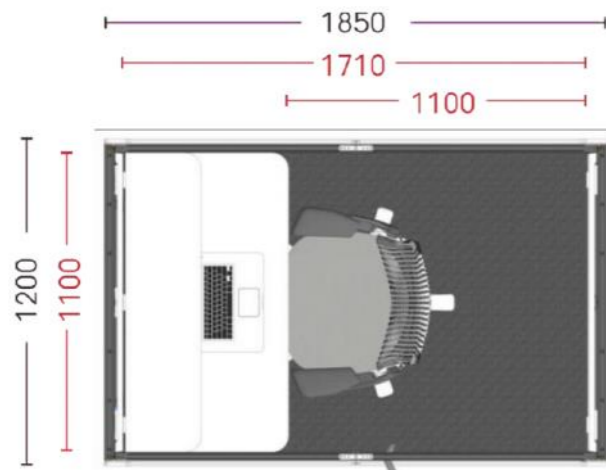

## Co-Work Room/Discussion POD

AMP02

### Description

Interior fabric: A-28

Exterior Fabric: A-28

Edge: Similar colour as fabric

Furniture: Shelf

### Outlet locations:

The 3<sup>rd</sup> panel on the left wall.

Dimmer switch (1), Data (1)

The 3<sup>rd</sup> panel on the right wall.

Power (1), USB (1)

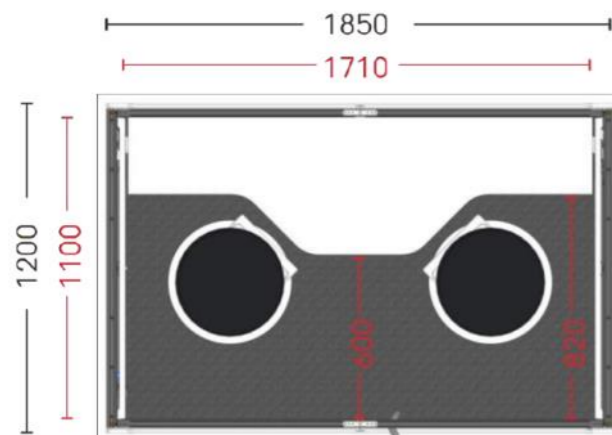

## Meeting Room

AMP04

### Description

Interior fabric: A-28

Exterior Fabric: A-28

Edge: Similar colour as fabric

Furniture: High meeting table + Shelf +

TV bracket + White board

### Outlet locations:

The 3<sup>rd</sup> panel on the left wall.

Dimmer switch (1)

Floor outlet for meeting table

Meeting table includes: Power (2), USB (1), Data (1)

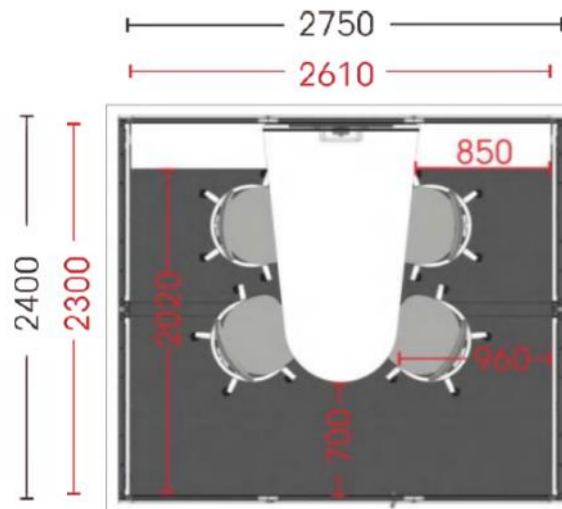

## Meeting Room

AMP04

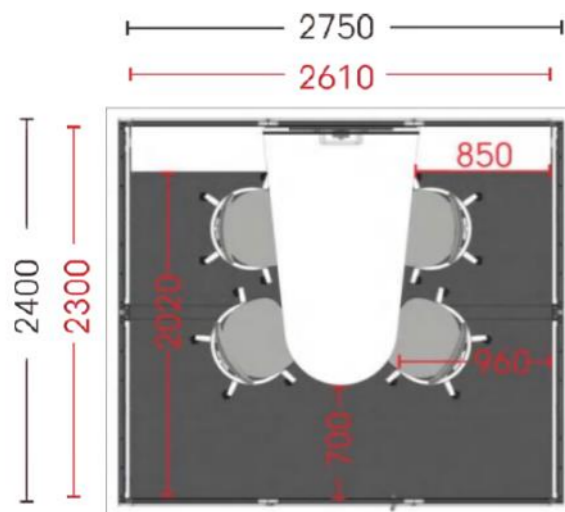

## Lounge

AMP04

### Description

Interior fabric: A-28

Exterior Fabric: A-28

Edge: Similar colour as fabric

Furniture: Shelf + TV bracket

### Outlet locations:

The 3<sup>rd</sup> panel on the left wall A.

Dimmer switch (1), Power (1), from floor outlet

The 4<sup>th</sup> panel on the left wall A, Power (1)

The 5<sup>th</sup> panel on the left wall A, Outlet (1)

The 4<sup>th</sup> panel on the left wall B, Power (1)

Power (1), from floor outlet for coffee table

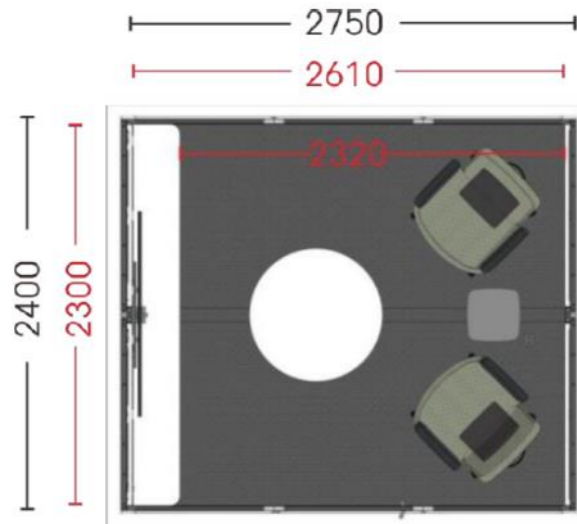

# Workplace Designs

Architecture | Project Consultancy | Furniture | CAD & Graphics

## Lounge

AMP04

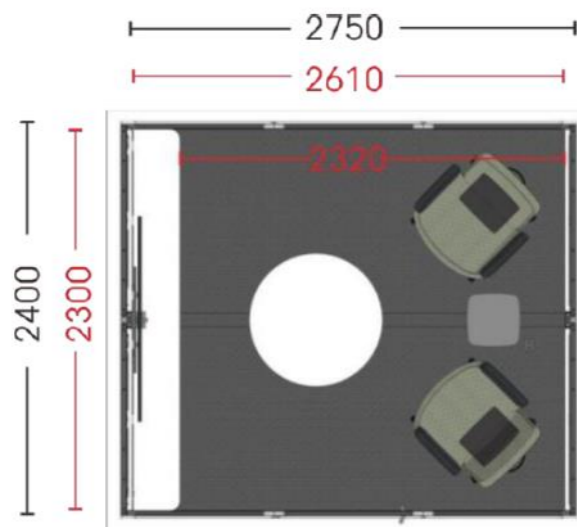



# Workplace Designs

Architecture | Project Consultancy | Furniture | CAD & Graphics

## Office

AMP04

### Description

Interior fabric: A-28

Exterior Fabric: A-28

Edge: Similar colour as fabric

Furniture: Shelf

### Outlet locations:

The third panel on the left wall A.

Dimmer switch (1)

The 4<sup>th</sup> panel on the left wall A, Power (1)

The 5<sup>th</sup> panel on the left wall A, Power (1)

The 4<sup>th</sup> panel on the left wall B, USB (1)

Power (1), from floor outlet for work table.

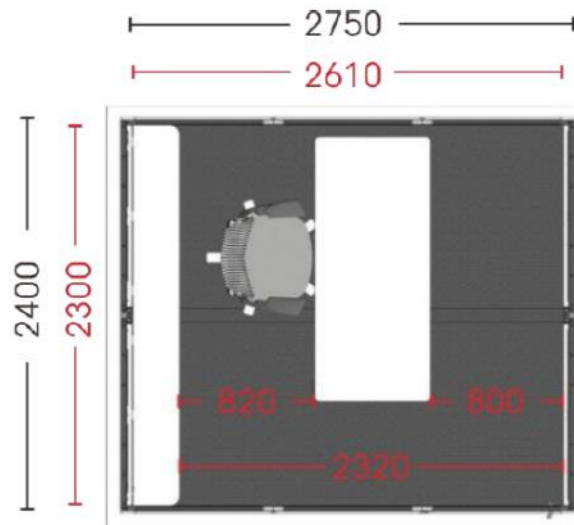

# Workplace Designs

Architecture | Project Consultancy | Furniture | CAD & Graphics

## Office

AMP04

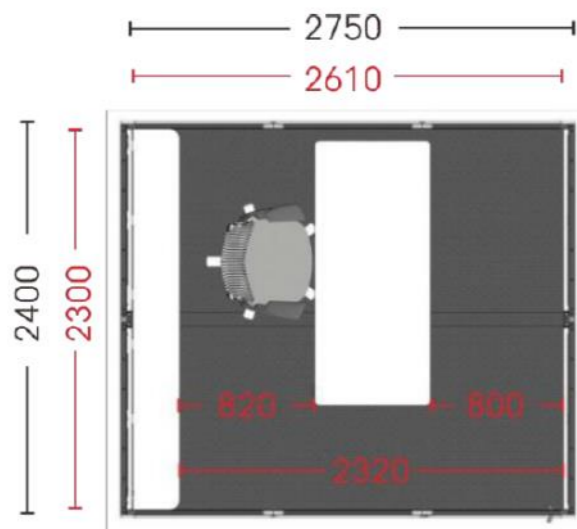

## Meeting Room

AMP04

### Description

Interior fabric: A-28

Exterior Fabric: A-28

Edge: Similar colour as fabric

Furniture: Meeting table + Shelf +

TV bracket + White board

### Outlet locations:

The 3<sup>rd</sup> panel on the left wall A.

Dimmer switch (1), Power (1)

The 5<sup>th</sup> panel on the right wall A.

Outlet (1) for meeting table.

Meeting table includes: Power (1), USB (1), Data (1)

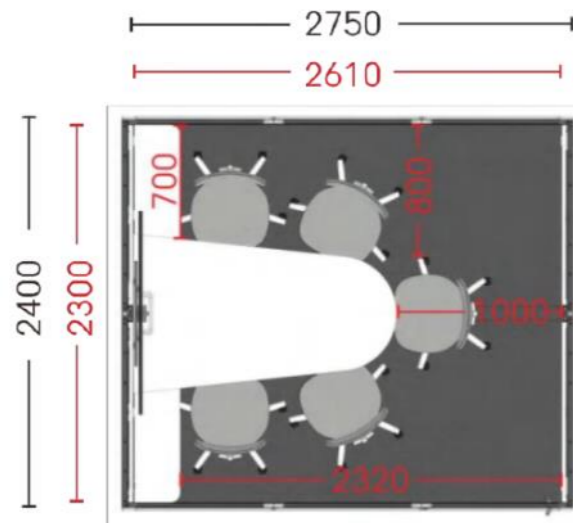

## Meeting Room

AMP04

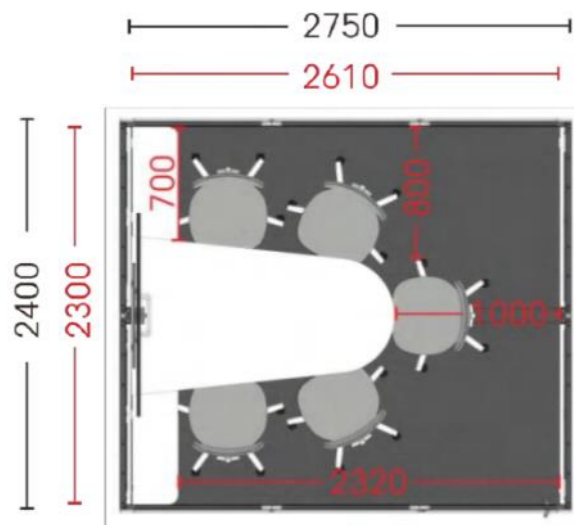

## Technical specifications

AMP01



Sound insulation: Sound level reduced by 30dB

Ventilation: Air change rate is every 60 seconds – 2 x fans,  
Power input: DC12V, 0.15A, 50-60 Hz  
RPM: 1500

Lighting: Colour temperature is 4000K, Ra90,  
light efficiency is 84lm/W  
Power input: DC12V, 0.85A, 50-60 Hz

Sensor: PIR

Dimmer switch: dimmable

Sockets:  
Standard: Power(1), USB socket (1), Data (1).  
Power sockets are available as universal to accommodate plugs of various types of choice.

AV bracket holds 40-75inch TV.

Wheels: Standard

Door closer: Optional

Occupancy indicator: Optional

Size:  
Outside: W1000-H2300-D1200mm  
Inside: W860-H2150-D1100mm

Space: 1.2m<sup>2</sup>

Furniture Configuration: Flexible

Main structure: steel frame, with quality assurance.

Solid wall, ceiling, floor: Carbon crystal board (with PET film) + polyester fibre sound-absorbing cotton

Glass wall: 8mm tempered glass + aluminium

Glass door: 10mm (5+5) laminated glass + steel frame

Exterior:

Decorative edge: Aluminium base sprayed with environmentally friendly automotive paint.

Exterior surface: White colour (Carbon crystal board ,with PET film), can be used as a writing board.

Fabric cover: Patented design for quick wrapping

Steel surface: Customizable with MOQ

Interior: Patented design integrated moulded plastic baseboard + sound absorbing cotton and decorative fabric.

Door: Left opening\right opening, can be switched, if required.

Function expansion slot: Pre-set.

Locations for installation of sockets: 72 positions pre-set in total for wall, floor, and ceiling.

Wiring channel:

Main channel: Power transformer and ventilator, LED lamp power line channel, already activated before delivery.

## Technical specifications

AMP02



Sound insulation: Sound level reduced by 30dB

Ventilation: Air change rate is every 60 seconds – 4 x fans,  
Power input: DC12V, 0.15A, 50-60 Hz  
RPM: 1500

Lighting: Colour temperature is 4000K, Ra90,  
light efficiency is 84lm/W  
Power input: DC12V, 0.85A, 50-60 Hz

Sensor: PIR

Dimmer switch: dimmable

Sockets:  
Standard: Power(1), USB socket (1), Data (1).  
Power socket has several national standards for choice.

AV bracket holds 40-75inch TV.

Wheels: Optional

Door closer: Optional

Occupancy indicator: Optional

Size:  
Outside: W1850-H2300-D1200mm  
Inside: W1710-H2150-D1100mm

Space: 2.2m<sup>2</sup>

Furniture Configuration: Flexible

Main structure: steel frame, with quality assurance.

Solid wall, ceiling, floor: Carbon crystal board (with PET film) +  
polyester fibre sound-absorbing cotton

Glass wall: 8mm tempered glass + aluminium

Glass door: 10mm (5+5) laminated glass + steel frame

Exterior:

Decorative edge: Aluminium base sprayed with environmentally  
friendly automotive paint.

Exterior surface: White colour (Carbon crystal board ,with PET film),  
can be used as a writing board.

Fabric cover: Patented design for quick wrapping

Steel surface: Customizable with MOQ

Interior: Patented design integrated moulded plastic baseboard +  
sound absorbing cotton and decorative fabric.

Door: Left opening\right opening, can be switched, if required.

Function expansion slot: Pre-set.

Locations for installation of sockets: 96 positions pre-set in total for  
wall, floor, and ceiling.

Wiring channel:

Main channel: Power transformer and ventilator, LED lamp power line  
channel, already activated before delivery.

## Technical specifications

AMP04

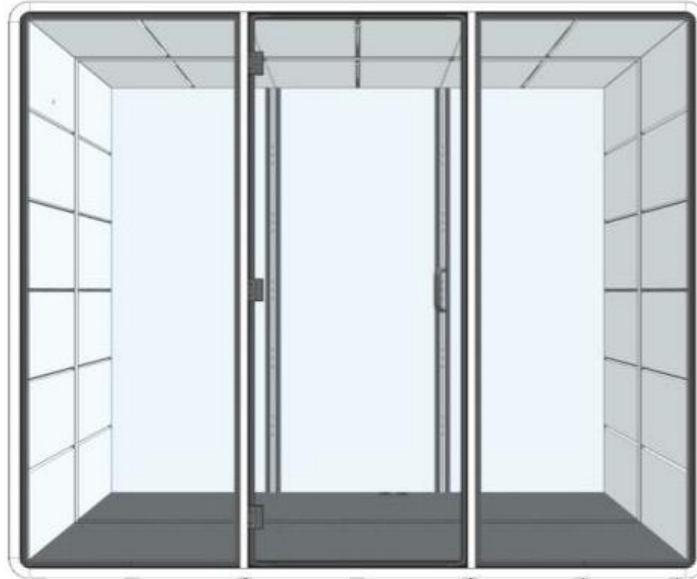

Sound insulation: Sound level reduced by 30dB

Ventilation: Air change rate is every 60 seconds – 16 x fans,  
Power input: DC12V, 0.15A, 50-60 Hz  
RPM: 1500

Lighting: Colour temperature is 4000K, Ra90,  
light efficiency is 84lm/W  
Power input: DC12V, 0.85A, 50-60 Hz

Sensor: PIR

Dimmer switch: dimmable

Sockets:  
Standard: Power(1), USB socket (1), Data (1).  
Power socket has several national standards for choice.

AV bracket holds 40-75inch TV.

Wheels: Optional

Door closer: Optional

Occupancy indicator: Optional

Size:  
Outside: W2750-H2300-D2400mm  
Inside: W2610-H2150-D2300mm

Space: 6.6m<sup>2</sup>

Furniture Configuration: Flexible

Main structure: steel frame, with quality assurance.

Solid wall, ceiling, floor: Carbon crystal board (with PET film) +  
polyester fibre sound-absorbing cotton

Glass wall: 8mm tempered glass + aluminium

Glass door: 10mm (5+5) laminated glass + steel frame

Exterior:

Decorative edge: Aluminium base sprayed with environmentally  
friendly automotive paint.

Exterior surface: White colour (Carbon crystal board ,with PET film),  
can be used as a writing board.

Fabric cover: Patented design for quick wrapping

Steel surface: Customizable with MOQ

Interior: Patented design integrated moulded plastic baseboard +  
sound absorbing cotton and decorative fabric.

Door: Left opening\right opening, can be switched, if required.

Function expansion slot: Pre-set.

Locations for installation of sockets: 240 positions pre-set in total for  
wall, floor, and ceiling.

Wiring channel:

Main channel: Power transformer and ventilator, LED lamp power line  
channel, already activated before delivery.

## Dimensions

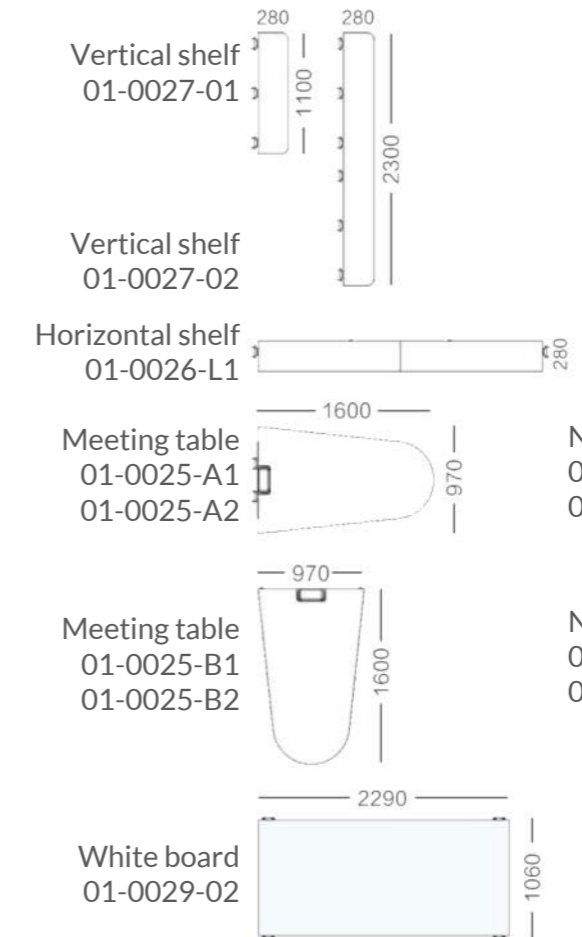
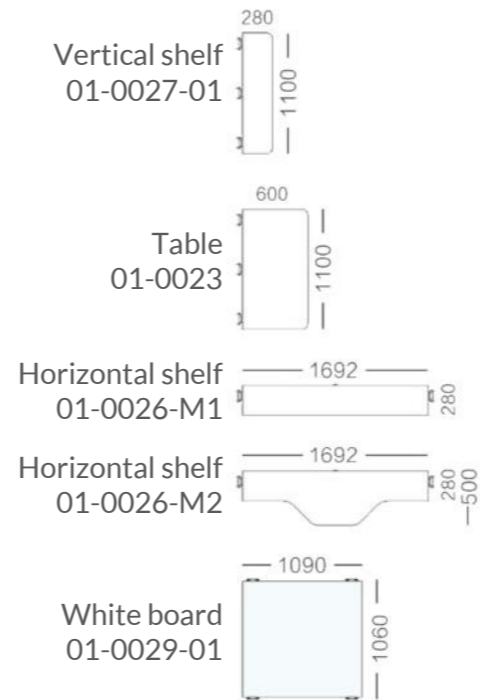
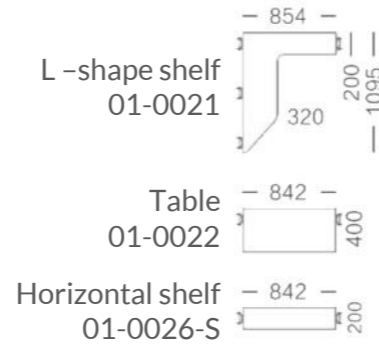
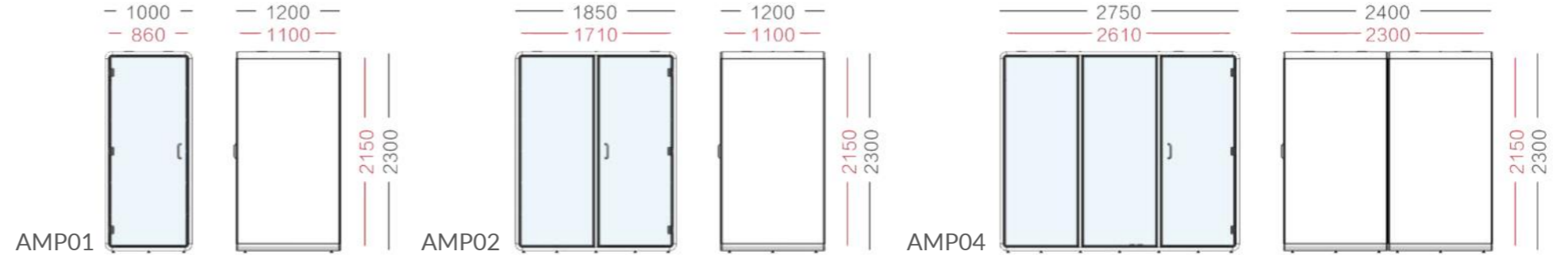

Note:  
01-0025-A1: Height 740mm  
01-0025-A2: Height 1050mm

Note:  
01-0025-B1: Height 740mm  
01-0025-B2: Height 1050mm

### Optional examples:

1. AMP-L2 (1)
2. 01-0025-A1 (1)
3. 01-0028-A (1)
4. 01-0027-01 (2)
5. 01-0029-02 (1)

Note: Please select the finish colours for AMP, including interior, exterior, and edge colours;

If AMP requires 2 doors, please specify when placing the order;

TV bracket 01-0028-A



TV bracket 01-0028-B



## Glass Manifestation

It is important to award of the health and safety requirement to apply manifestations to glass doors, glass partitions and screens.

If you have full height glass in windows, doors or building partitions, they must be marked correctly with glass manifestation to make sure the solid glass is evident.

Different text font design and size are available to suit your design needs.

AMP01

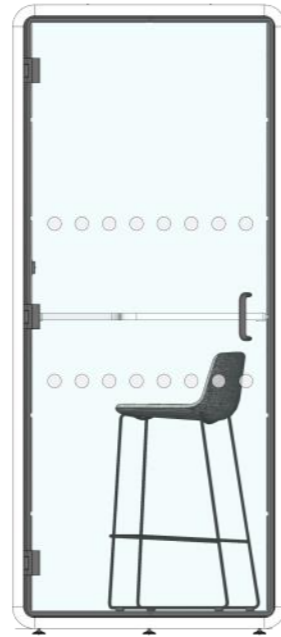

AMP02



AMP04

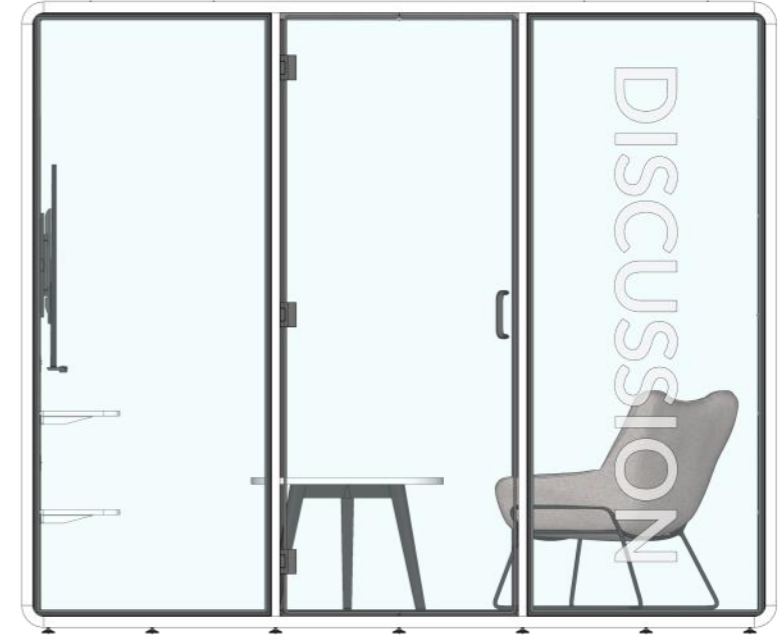
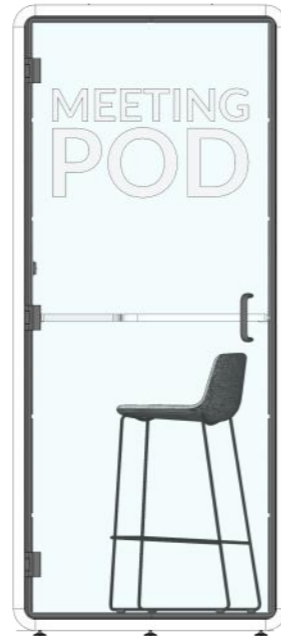
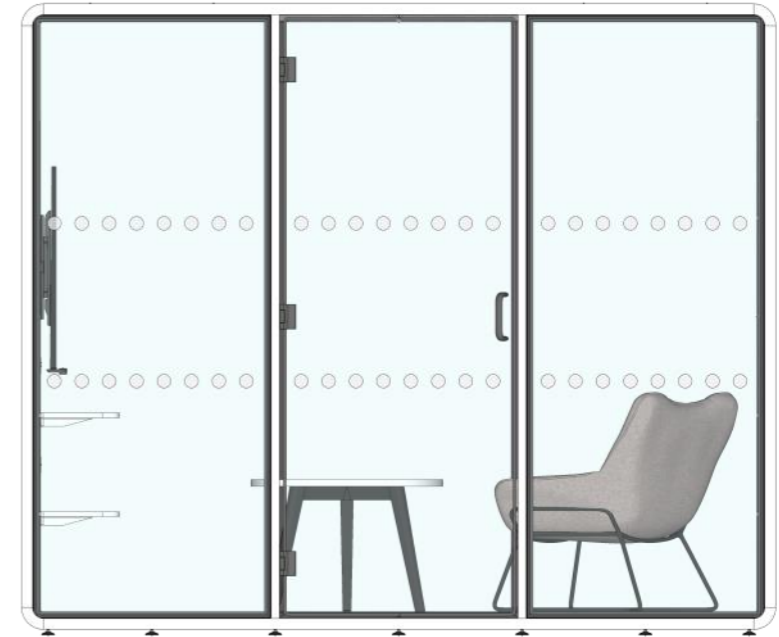

## Colours and finishes

AMP's replaceable finishes include: interior fabric, exterior fabric and aluminium door edges, which can be fully or partially changed according to the user's preference.

The frames have an aluminium surfaces which are finished with a coat of environmentally friendly automotive paint, selected from the "RAL-K5" colour card.



Thank you

# Workplace Designs

Architecture | Project Consultancy | Furniture | CAD & Graphics

Unit 420 | Omnibus Business Centre | 39-41 North Road | London N7 9DP